



**Urgent Field Safety Notice**  
**Product Correction**  
 Urgent - Immediate Action Required

**Date Issued** September 16, 2019

**Product**

Product Name	List Number (LN)	Serial Number	UDI
Alinity ci Level Sensor, Bulk Solution	04S68-02	All	N/A
Accessory kit, Alinity i	03R66-03	All	N/A
Accessory kit #2, Alinity c	03R69-03 03R69-04	All	N/A

**Summary**

Abbott has identified a potential reliability issue with the Alinity ci-series Level Sensor, Bulk Solution (LN 04S68-02). The details of the issue and the potential impact is described below.

Abbott has redesigned Level Sensor, Bulk Solution (LN 04S68-02) to improve reliability. The redesigned Level Sensor, Bulk Solution (LN 04S68-03) will be available beginning in the fourth quarter of 2019. You may continue to run the system using part number (LN 04S68-02) until the replacement parts (LN 04S68-03) are obtained by taking the recommended actions outlined in this letter. Once the redesigned Level Sensor, Bulk Solution (LN 04S68-03) is available, Abbott recommends the replacement of the LN 04S68-02 in all positions on the Alinity c and i systems.

We sincerely regret any inconvenience this may have caused your laboratory.

**Explanation**

The development of environmental stress on the bulk solution level sensor can cause cracks. Cracks can allow air to enter the fluid line, which may result either a failure to dispense or an incomplete dispense of the bulk solution on Alinity i and Alinity c.

**Alinity i**

A reduced dispense volume of Trigger Solution or Pre-Trigger Solution will cause an unexpectedly low RLU (relative light unit) reading, resulting in lower than expected values for direct assays (upward slope calibration curves), or higher than expected values in indirect assays (downward slope calibration curves). These events may be accompanied by message codes 1043, 1044, 1072, 1402 or 1403 and potentially impact patient results. A leak in the level sensor associated with the Concentrated Wash Buffer will not impact patient results as the system will detect the change in solution conductivity and prevent testing.

**Alinity c**

A failure to dispense Acid Wash or Alkaline Wash may lead to inadequate washing of the cuvettes. This may cause carryover which could impact patient results. These events may be accompanied by message codes 3687 or 3689. ICT Results are not impacted by this issue.

**Patient  
Impact**

Cracks in the Alinity ci-series bulk solution level sensor at the Trigger Solution, Pre-Trigger Solution, Acid Wash or Alkaline Wash reservoirs have the potential to impact patient results on the Alinity c and the Alinity i.

**Necessary  
Actions**

If....	Then...
<b>Alinity i:</b> If you receive one of the following message codes: 1043, 1044, 1072, 1402, 1403. Refer to Appendix B.	<ul style="list-style-type: none"><li>• Discontinue reporting results until troubleshooting is complete</li><li>• Inspect the Alinity ci-series bulk solution level sensors per the instructions in Appendix A</li><li>• If a bulk solution level sensor is found to be cracked:<ul style="list-style-type: none"><li>○ Replace the part before running the system using the replacement instructions found in the Alinity ci-series Operations Manual.</li><li>○ Abbott recommends following your laboratory procedure to review results produced since your last successful Quality Control (QC).</li></ul></li><li>• If the level sensor is not cracked, refer to the Alinity ci-series Operations Manual to troubleshoot for the specific message code.</li></ul>
<b>Alinity c:</b> If you receive one of the following message codes: 3687, 3689. Refer to Appendix B.	
<p><b>Weekly maintenance of the bulk solution level sensor:</b></p> <p>Please inspect the Alinity ci-series bulk solution level sensors per the instructions in Appendix A. If a bulk solution level sensor is found to be cracked, replace the part before running the system using the replacement instructions found in the Alinity ci-series Operations Manual. Abbott recommends following your laboratory procedure to review results produced since your last successful QC.</p> <p>To assist in the detection of a cracked bulk solution level sensor, Abbott recommends running Quality Control (QC) immediately before performing this weekly maintenance.</p> <p>Once the redesigned level sensor (LN 04S68-03) is installed on your Alinity system, you may discontinue the weekly inspection; however, continue to troubleshoot message codes per the Alinity ci-series Operations Manual.</p>	
<p><b>Previously generated results:</b> The following messages are potentially associated with a cracked bulk solution level sensor and incorrect results.</p> <ul style="list-style-type: none"><li>• Alinity i: 1043, 1044, 1072, 1402, 1403</li><li>• Alinity c: 3687, 3689</li></ul> <p>If your laboratory had previously identified cracks on the bulk solution level sensor before receipt of this communication, and there are messages associated with patient results in the Alinity ci-series System Logs during the same time period, Abbott recommends following your laboratory procedure to review results produced from the replacement of the bulk solution level sensor to the previous successful Quality Control (QC) before the occurrence of messages associated with incorrect results.</p>	

If you have forwarded the product listed above to other laboratories, please inform them of this Product Correction and provide to them a copy of this letter.

Please retain this letter for your laboratory records.

---

**Contact  
Information**

If you or any of the health care providers you serve have any questions regarding this information, U.S. Customers please contact Customer Service at 1-877-4ABBOTT (available 24 hours a day, 7 days a week). Customers outside the U.S., please contact your local area Customer Service.

Adverse reactions or quality problems experienced with the use of this product may be reported to the FDA's MedWatch Adverse Event Reporting program via online (<http://www.fda.gov/MedWatch/report.htm>), by mail (<http://www.fda.gov/MedWatch/getforms.htm>), by phone (1-800-332-1088), or by fax (1-800-FDA-0178).

If you have experienced any patient or user injury associated with this Field Action, please immediately report the event to your local area Customer Service.

---

## Appendix A: Alinity ci-series Bulk Level Sensor Inspection Instructions:



**CAUTION: Chemical Hazard.** This activity or area exposes you to a chemical hazard.

1. Open the bulk solution door and pull out the reservoir tray.  
NOTE: Use caution when handling the bulk solution level sensors. Avoid applying stress on the wiring and the connector.
2. Locate each level sensor.



*Bulk solution reservoir components (Alinity i)*

1. Concentrated Wash Buffer level sensor
2. Trigger Solution level sensor
3. Pre-Trigger Solution level sensor

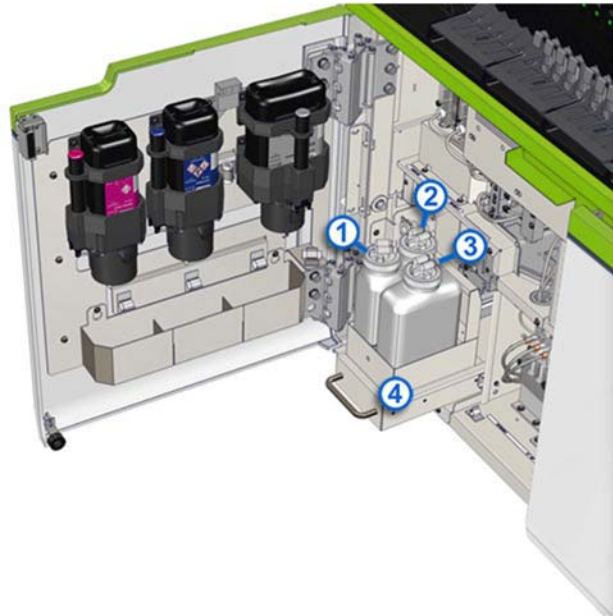

*Bulk solution reservoir area (Alinity c)*

1. Alkaline Wash level sensor
2. Acid Wash level sensor
3. ICT Reference Solution level sensor
4. Reservoir bottle tray

3. Inspect the inlet and outlet ports of each level sensor for cracks.

**Note:**

- Crack size and location on inlet and outlet ports is variable. See Figure 1.
  - On each level sensor, there is a “knit” line that is a normal outcome from the manufacturing process. The “knit” line is not a crack or defect in the level sensor. See Figure 2.
4. If crack(s) are detected,
    - Replace the bulk level sensor. LN 04S68-02 may be used until LN 04S68-03 is available. For replacement instructions, refer to the Alinity ci-series Operations Manual, Section 9.
    - Review results generated from the last successful quality control.
  5. When the inspection is complete slide the reservoir bottle tray into the bulk solution reservoir area and close the bulk solution door.

**Figure 1. Examples of cracked level sensor (Not Acceptable)**

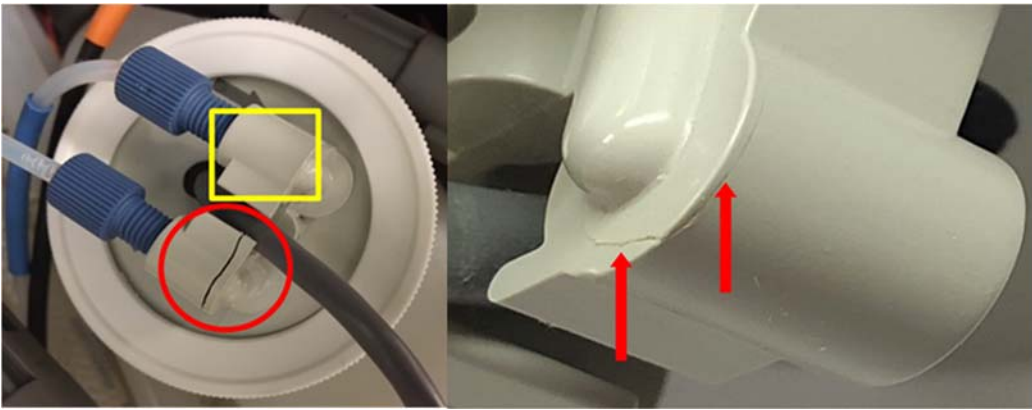

- Area in red circle indicates level sensor crack.
- Area in yellow square indicates undamaged port.
- Area with red arrows indicates cracks.

**Figure 2. Example of knit line from manufacturing process (Acceptable)**



**Figure 3. Identification of the Level Sensor, Bulk Solution (LNs 04S68-02 and 04S68-03)**

(a) Level Sensor, Bulk Solution LN 04S68-02, (b) Level Sensor, Bulk Solution LN 04S68-03

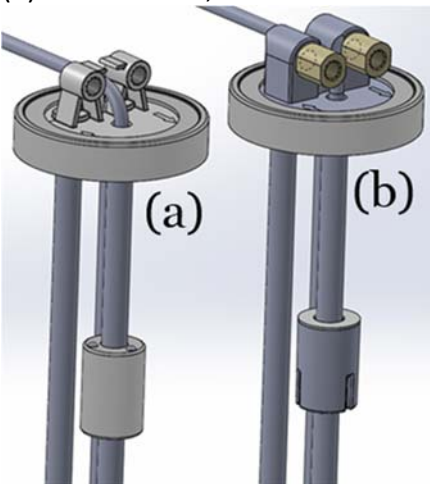

## Appendix B: Message codes associated with cracked bulk solution level sensor

Message Code	Description
1043	Unable to calculate result. Final RLU read is outside the specification of the highest calibrator.
1044	Unable to calculate result. Final RLU read is outside the specification of the lowest calibrator.
1072	Unable to calculate result. Processing module response outside of defined range.
1402	Unable to process test. Activated read failure.
1403	Unable to process test. Final read failure.
3687	No aspiration detected for Acid Wash reservoir. Current level sensor ADC (0), previous level sensor ADC (1) and aspiration count (2). 0 = Current ADC level 1 = Previous ADC level 2 = Aspiration count
3689	No aspiration detected for Alkaline Wash reservoir. Current level sensor ADC (0), previous level sensor ADC (1) and aspiration count (2). 0 = Current ADC level 1 = Previous ADC level 2 = Aspiration count