



W.O.M. WORLD OF MEDICINE GmbH | Salzufer 8 | 10587 Berlin

Enter Address

Berlin, 17.09.19

Urgent Field Safety Notice (FSN) Aquilex Fluid Control System (AQL-100CBS)

WOM reference no.: Recall_AQL100-CBS_001

Information on Affected Devices:

The Aquilex Fluid Control System is intended to provide fluid distension of the uterus during diagnostic and operative hysteroscopy, and to monitor the volume differential between the irrigation fluid flowing into and out of the uterus.

The purpose of this letter is to inform you that a component of your Aquilex Fluid Control System, the Fluid Monitoring System (AQL-100CBS), is subject to a Field Safety Corrective Action.

The Aquilex Fluid Management Pump (AQL-100P / AQL-100PBS) and Aquilex Fluid Management tube sets (AQL-110, AQL-111 and AQL-114) as well as all other components are not impacted by this recall.

Affected serial numbers:

A list of affected serial numbers can be found in Annex 1

Reason for Field Safety Corrective Action (FSCA)

WOM has received some complaints regarding incorrect fluid deficit measurements. If the displayed fluid deficit is lower than the actual deficit the patient could be overexposed to distention media. Exceeding the deficit limit can lead to a serious risk such as gynaecological TUR syndrome (when using electrolyte-free solutions are used as distending media) or pulmonary/cerebral edemas (when using electrolyte-containing solutions).

This potential incorrect display of fluid deficit has been attributed to lose or lost bag deflectors on the cart scales.

No serious adverse events or deaths have been reported related to this Field Safety Corrective Action.



Recommendation for users:

Please perform a visual inspection of your Aquilex system looking for obvious damage to the bag deflector using the criteria in Annex 2. If you notice **any damage or abnormality** during the inspection, please **stop using your Aquilex Fluid Control System**. Contact your local representative to arrange replacement as soon as possible.

Perform a Fluid Deficit Measurement Test (FDM-test). The fluid deficit measurement test is described in chapter 9.2.4 of the Instructions for Use. Annex 3 provides also a detailed instruction on how to perform this test. The displayed fluid deficit after the test should be 0 ml with permissible tolerance is ± 50 ml. If the Fluid Deficit Measurement Test is **not passed successfully**, please **stop using your Aquilex Fluid Control System**. Contact your local representative to arrange replacement as soon as possible.

If both visual inspection and the FDM-test are passed successfully, you may continue to use your unit. The affected unit still needs to be returned to W.O.M (manufacturer) within the coming month. Please contact your local representative to arrange a replacement.

Transmission of this Field Safety Notice:

This notice should be provided to all personnel who need to be made aware of this issue within your organization.

The Competent (Regulatory) Authority of your country has been informed about this communication to customers.

Please acknowledge the receipt of this Field Safety Notice by returning the Customer Reply Form to:

be-reception@hologic.com

Attachments:

- Annex 1: list of affected units
- Annex 2: Visual Inspection Instructions
- Annex 3 Aquilex Fluid Deficit Measurement Instruction

Urgent Field Safety Notice AQL-100CBS – Annex 1
List of affected serial numbers

1802CE0558	1803CE0226	1803CE0835	1804CE0075	1804CE0487	1804CE0912	1805CE0592
1802CE0559	1803CE0227	1803CE0869	1804CE0153	1804CE0488	1804CE0913	1805CE0593
1802CE0560	1803CE0228	1803CE0870	1804CE0154	1804CE0489	1804CE0914	1805CE0594
1802CE0561	1803CE0229	1803CE0871	1804CE0155	1804CE0490	1804CE0915	1805CE0595
1802CE0562	1803CE0230	1803CE0872	1804CE0156	1804CE0491	1804CE0916	1805CE0596
1802CE0563	1803CE0231	1803CE0873	1804CE0157	1804CE0492	1804CE0917	1805CE0597
1802CE0564	1803CE0232	1803CE0874	1804CE0158	1804CE0493	1804CE0918	1805CE0598
1802CE0565	1803CE0233	1803CE0875	1804CE0159	1804CE0494	1804CE0919	1805CE0599
1802CE0566	1803CE0234	1803CE0876	1804CE0160	1804CE0495	1804CE0920	1805CE0600
1802CE0567	1803CE0235	1803CE0877	1804CE0212	1804CE0648	1805CE0031	1805CE0640
1803CE0024	1806CE0520	1803CE0878	1804CE0213	1804CE0649	1805CE0032	1805CE0641
1803CE0025	1803CE0498	1803CE0926	1804CE0214	1804CE0650	1805CE0033	1805CE0642
1803CE0026	1803CE0499	1803CE0927	1804CE0215	1804CE0651	1805CE0034	1805CE0643
1803CE0027	1803CE0500	1803CE0928	1804CE0216	1804CE0652	1805CE0035	1805CE0644
1803CE0028	1803CE0501	1803CE0929	1804CE0217	1804CE0653	1805CE0036	1805CE0645
1803CE0029	1803CE0502	1803CE0930	1804CE0218	1804CE0654	1805CE0037	1805CE0646
1803CE0030	1803CE0503	1803CE0931	1804CE0219	1804CE0655	1805CE0038	1805CE0647
1803CE0031	1803CE0504	1803CE0932	1804CE0220	1804CE0656	1805CE0039	1805CE0648
1803CE0032	1803CE0505	1803CE0933	1804CE0221	1804CE0657	1805CE0040	1805CE0649
1803CE0033	1803CE0506	1803CE0934	1804CE0260	1804CE0737	1805CE0099	1805CE0742
1803CE0064	1803CE0507	1803CE0935	1804CE0261	1804CE0738	1805CE0100	1805CE0743
1803CE0065	1803CE0562	1803CE1118	1804CE0262	1804CE0739	1805CE0101	1805CE0744
1803CE0066	1803CE0563	1803CE1119	1804CE0263	1804CE0740	1805CE0102	1805CE0745
1803CE0067	1803CE0564	1803CE1120	1804CE0264	1804CE0741	1805CE0103	1805CE0746
1803CE0068	1803CE0565	1803CE1121	1804CE0265	1804CE0742	1805CE0104	1805CE0747
1803CE0069	1803CE0566	1803CE1122	1804CE0266	1804CE0743	1805CE0105	1805CE0748
1803CE0070	1803CE0567	1803CE1123	1804CE0267	1804CE0744	1805CE0106	1805CE0749
1803CE0071	1803CE0568	1803CE1124	1804CE0268	1804CE0745	1805CE0107	1805CE0750
1803CE0072	1803CE0569	1803CE1125	1804CE0269	1804CE0746	1805CE0108	1805CE0751
1803CE0073	1803CE0570	1803CE1126	1804CE0355	1804CE0791	1805CE0336	1806CE0214
1803CE0111	1803CE0571	1803CE1127	1804CE0356	1804CE0792	1805CE0337	1806CE0215
1803CE0112	1803CE0628	1803CE1168	1804CE0357	1804CE0793	1805CE0338	1806CE0216
1803CE0113	1803CE0629	1803CE1169	1804CE0358	1804CE0794	1805CE0339	1806CE0217

1803CE0114	1803CE0630	1803CE1170	1804CE0359	1804CE0795	1805CE0340	1806CE0218
1803CE0115	1803CE0631	1803CE1171	1804CE0360	1804CE0796	1805CE0341	1806CE0219
1803CE0116	1803CE0632	1803CE1172	1804CE0361	1804CE0797	1805CE0342	1806CE0220
1803CE0117	1803CE0633	1803CE1173	1804CE0362	1804CE0798	1805CE0343	1806CE0221
1803CE0118	1803CE0634	1803CE1174	1804CE0363	1804CE0799	1805CE0344	1806CE0222
1803CE0119	1803CE0635	1803CE1175	1804CE0364	1804CE0800	1805CE0345	1806CE0223
1803CE0120	1803CE0636	1803CE1176	1804CE0436	1804CE0841	1805CE0412	1806CE0308
1803CE0166	1803CE0637	1803CE1177	1804CE0437	1804CE0842	1805CE0413	1806CE0309
1803CE0167	1803CE0826	1804CE0066	1804CE0438	1804CE0843	1805CE0414	1806CE0310
1803CE0168	1803CE0827	1804CE0067	1804CE0439	1804CE0844	1805CE0415	1806CE0311
1803CE0169	1803CE0828	1804CE0068	1804CE0440	1804CE0845	1805CE0416	1806CE0312
1803CE0170	1803CE0829	1804CE0069	1804CE0441	1804CE0846	1805CE0417	1806CE0313
1803CE0171	1803CE0830	1804CE0070	1804CE0442	1804CE0847	1805CE0418	1806CE0314
1803CE0172	1803CE0831	1804CE0071	1804CE0443	1804CE0848	1805CE0419	1806CE0315
1803CE0173	1803CE0832	1804CE0072	1804CE0444	1804CE0849	1805CE0420	1806CE0316
1803CE0174	1803CE0833	1804CE0073	1804CE0445	1804CE0850	1805CE0421	1806CE0317
1803CE0175	1803CE0834	1804CE0074	1804CE0486	1804CE0911	1805CE0591	
1806CE0521	1808CE0850	1809CE0125	1809CE0831	1808CE1258	1809CE0695	
1806CE0522	1808CE0851	1809CE0126	1809CE0832	1808CE1259	1809CE0696	
1806CE0523	1808CE0852	1809CE0127	1809CE0833	1808CE1260	1809CE0697	
1806CE0524	1808CE0853	1809CE0128	1809CE0834	1808CE1261	1809CE0698	
1806CE0525	1808CE0854	1809CE0129	1809CE0835	1808CE1262	1809CE0699	
1806CE0526	1808CE0855	1809CE0130	1809CE0836	1808CE1263	1809CE0700	
1806CE0527	1808CE0856	1809CE0131	1809CE0837	1808CE1264	1809CE0701	
1806CE0528	1808CE0857	1809CE0132	1809CE0838	1808CE1265	1809CE0702	
1806CE0529	1808CE0858	1809CE0133	1809CE0839	1808CE1318	1809CE0830	
1807CE0781	1808CE0920	1809CE0154	1807CE0936	1808CE1319		
1807CE0782	1808CE0921	1809CE0155	1807CE0937	1808CE1320		
1807CE0783	1808CE0922	1809CE0156	1807CE0938	1808CE1321		
1807CE0784	1808CE0923	1809CE0157	1807CE0939	1808CE1322		
1807CE0785	1808CE0924	1809CE0158	1807CE0940	1808CE1323		
1807CE0786	1808CE0925	1809CE0159	1807CE0941	1808CE1324		
1807CE0787	1808CE0926	1809CE0160	1807CE0942	1808CE1325		
1807CE0788	1808CE0927	1809CE0161	1807CE0943	1808CE1326		
1807CE0789	1808CE0928	1809CE0162	1807CE0944	1808CE1327		
1807CE0790	1808CE0929	1809CE0163	1808CE0629	1809CE0124		
1807CE0855	1808CE1083	1809CE0220	1808CE0630	1809CE0572		

1807CE0856	1808CE1084	1809CE0221	1808CE0631	1809CE0573		
1807CE0857	1808CE1085	1809CE0222	1808CE0632	1809CE0574		
1807CE0858	1808CE1086	1809CE0223	1808CE0633	1809CE0575		
1807CE0859	1808CE1087	1809CE0224	1808CE0634	1809CE0576		
1807CE0860	1808CE1088	1809CE0225	1808CE0635	1809CE0577		
1807CE0861	1808CE1089	1809CE0226	1808CE0636	1809CE0578		
1807CE0862	1808CE1090	1809CE0227	1808CE0637	1809CE0579		
1807CE0863	1808CE1091	1809CE0228	1808CE0638	1809CE0580		
1807CE0864	1808CE1092	1809CE0229	1808CE0849	1809CE0693		
1807CE0935	1808CE1256	1809CE0571	1808CE1257	1809CE0694		

Urgent Field Safety Notice AQL-100CBS — Annex 2 Visual Inspection Instructions

- Check if the bag deflector (see picture below, item 3) is fitting properly and is not showing any damage or has become loose.

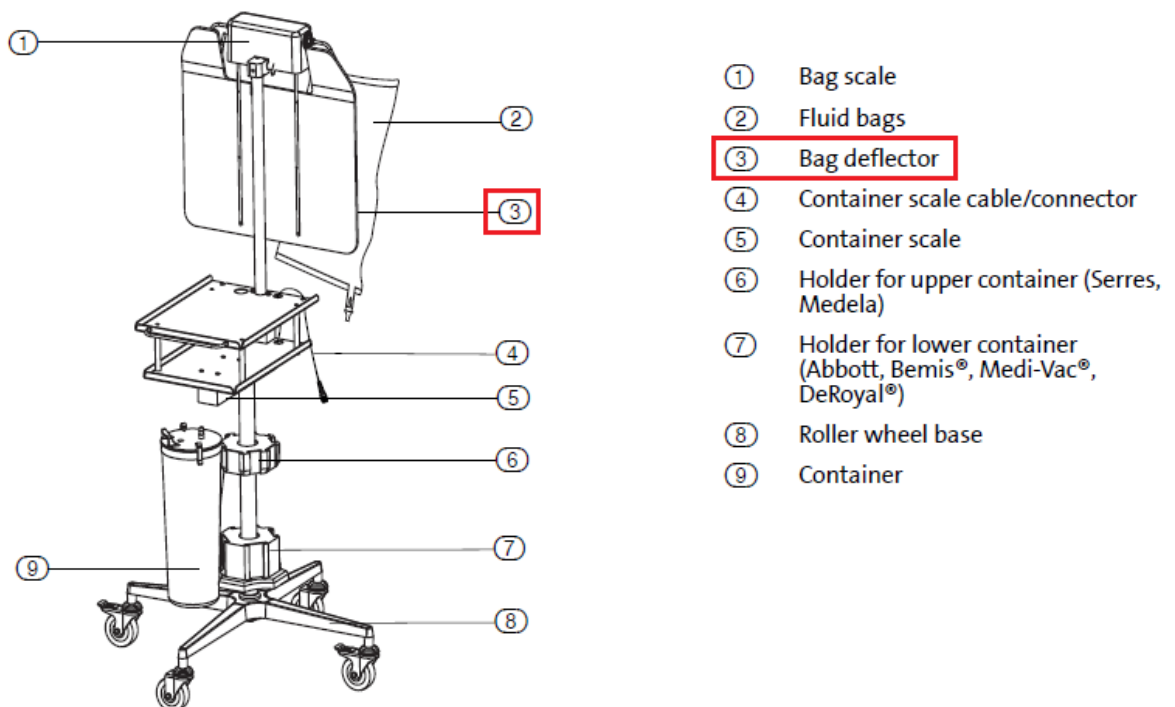

- The bag deflector must be properly installed, according to the figure identified above.
- Because the bag deflector is a co-weighed part of the scale it must hang straight and must not touch any parts of the pump nor the mounting pole of the bag scale.
- The bag deflector must not hang at an angle (seen from front and side).
- Mounting rods of the bag deflector must not be bent.
- Up and down movement must not be possible on either side of the mounting.
- The bag deflector must be firmly fastened to the load cell so that no upward or downward movement is possible.

Urgent Field Safety Notice AQL-100CBS – Annex 3 **Fluid Deficit Measurement Test Instructions**

It is critical that the collection container is positioned on the scale. The outflow tube set must not rest on the collection container, but the fluid must be collected in the container.

1. Assure that the inflow bag contains at least 1.5 l fluid, to prevent the bag from running empty during the test procedure. Hang the fluid bag onto one of the hooks of the bag scale.
2. Position one collection container properly in the respective holders of the container scale. Use one of the places on the back of the scale.
3. Turn the system on.
4. Once the display depicts **Insert Tube Set**, insert a tube set into the pump and close clamps on the bags.
5. Insert the tap spike into the fluid bag and open the related clamp.
6. Fasten the other end of the tube in the recesses on the back of the pump tray (see photo on the right) so that the tube end with the luer lock hangs freely in the container.
7. Place the middle tube section e.g. on the pump so that it does not touch either the Container Scale or the Bag Scale.
8. Press the **PRIME** button to start the calibration, which fills the tube set completely with fluid.
9. Once the display depicts **Prime Successful Close Stopcock**, press the **Pause/Resume** button to stop fluid transport,
10. Set the fluid deficit display to zero by pressing the **Zero** button
11. Press the **Pause/Resume** button to start fluid transport.
12. Allow system to run for 1 minute (use a stopwatch).
13. Press the **Pause/Resume** button to stop fluid transport

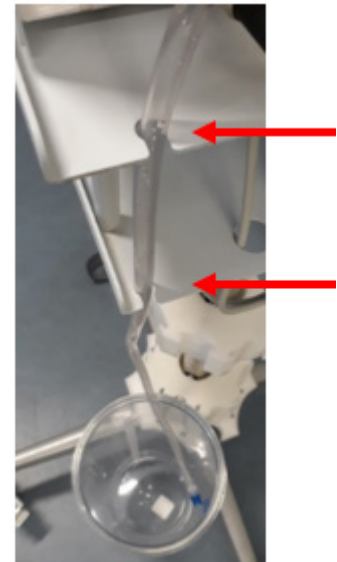

14. The displayed fluid deficit should be 0 ml.
The permissible tolerance is ± 50 ml.



Urgent Field Safety Notice AQL-100CBS

Customer Reply Form

- I confirm receipt of the Field Safety Notice and that I read and understood its content.
- I have/will perform the actions as described in the Field Safety Notice have been brought to the attention of all relevant users.
- The information and required actions in the Field Safety Notice have been brought to the attention of all relevant users.
- I do not have, or no longer have an Aquilex Fluid Control System at my facility.

Institution: _____

Name: _____

Phone/E-mail: _____

Address: _____

City: _____

Country: _____

Date: ____ / ____ / 20____ Signature: _____

It is important that your organization takes the actions detailed in this letter and confirms that you have received this notice for regulatory tracking purposes.

Please e-mail scanned copy to:
be-reception@hologic.com